

Controlling Motors (H-Bridges & L293D)

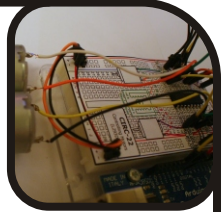

The Schematic

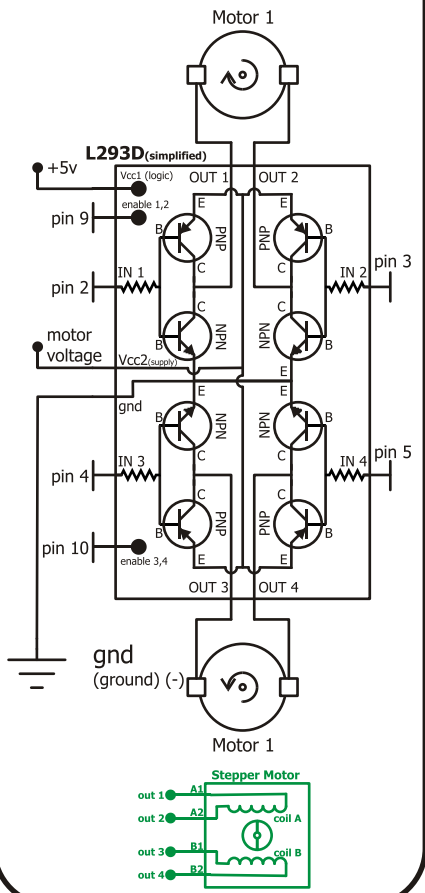

The Theory & Code

Controlling Motors

While turning a motor on and off requires only one switch (or transistor) controlling the direction is deceptively difficult. It requires no fewer than four switches (or transistors) arranged in a clever way.

H-Bridges

These four switches (or transistors) are arranged in a shape that resembles an 'H' and thus called an H-Bridge. Each side of the motor has two transistors, one is responsible for pushing that side HIGH the other for pulling it LOW. When one side is pulled HIGH and the other LOW the motor will spin in one direction. When this is reversed (the first side LOW and the latter HIGH) it will spin the opposite way.

DC Motor Example

Confused? that's alright it all starts making sense with an example. Cut out the breadboard layout sheet below and download the example code from <http://tinyurl.com/qcph9> and play around.

Stepper Motor Example (for use with 4, 5,6 & 8 wire motors)

The Arduino IDE has an included library for controlling stepper motors. To test it out with this setup, plug the stepper motor in with coil A across OUT 1 & 2, and coil B across OUT 3 & 4. Then download example code from <http://tinyurl.com/nyylun> and play around.

:: Arduino IDE Stepper Library Reference <http://tinyurl.com/kvquny> ::
:: L293D Datasheet <http://tinyurl.com/l37lw9> ::

The Pin-out

1,2EN-1	16-Vcc1(logic)
1IN-2	15-4IN
1OUT-3	14-4OUT
gnd-4	13-gnd
gnd-5	12-gnd
2OUT-6	11-3OUT
2IN-7	10-3IN
(supply)Vcc2-8	9-3,4EN

The Limits

::Current Per Channel::

600 mA

(max peak 1.2A)

(under heavy loads the chip will get quite hot and may need additional heat-sinking.)

It also has thermal protection so will shutdown before breaking)

The Circuit

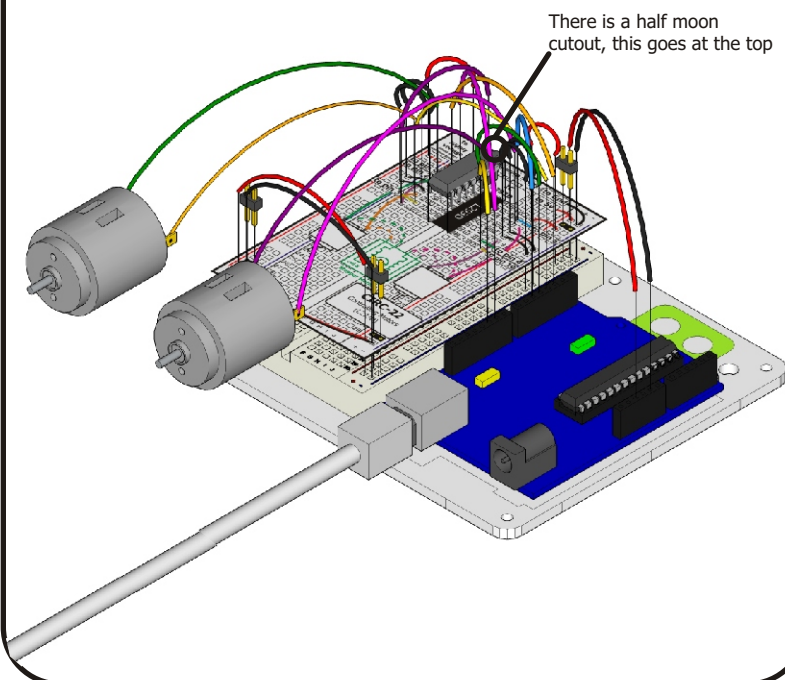

The Layout Sheet

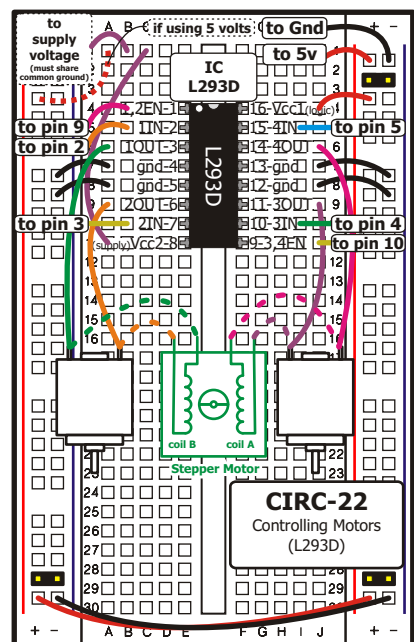

:: Instructions: print out, cut out, get making ::
:: for more details visit: <http://tinyurl.com/nsuwln> ::